

Архангельск (8182)63-90-72  
Астана (7172)727-132  
Астрахань (8512)99-46-04  
Барнаул (3852)73-04-60  
Белгород (4722)40-23-64  
Брянск (4832)59-03-52  
Владивосток (423)249-28-31  
Волгоград (844)278-03-48  
Вологда (8172)26-41-59  
Воронеж (473)204-51-73  
Екатеринбург (343)384-55-89  
Иваново (4932)77-34-06

Ижевск (3412)26-03-58  
Иркутск (395)279-98-46  
Казань (843)206-01-48  
Калининград (4012)72-03-81  
Калуга (4842)92-23-67  
Кемерово (3842)65-04-62  
Киров (8332)68-02-04  
Краснодар (861)203-40-90  
Красноярск (391)204-63-61  
Курск (4712)77-13-04  
Липецк (4742)52-20-81  
Киргизия (996)312-96-26-47

Магнитогорск (3519)55-03-13  
Москва (495)268-04-70  
Мурманск (8152)59-64-93  
Набережные Челны (8552)20-53-41  
Нижегород (831)429-08-12  
Новокузнецк (3843)20-46-81  
Новосибирск (383)227-86-73  
Омск (3812)21-46-40  
Орел (4862)44-53-42  
Оренбург (3532)37-68-04  
Пенза (8412)22-31-16  
Россия (495)268-04-70

Пермь (342)205-81-47  
Ростов-на-Дону (863)308-18-15  
Рязань (4912)46-61-64  
Самара (846)206-03-16  
Санкт-Петербург (812)309-46-40  
Саратов (845)249-38-78  
Севастополь (8692)22-31-93  
Симферополь (3652)67-13-56  
Смоленск (4812)29-41-54  
Сочи (862)225-72-31  
Ставрополь (8652)20-65-13  
Казахстан (772)734-952-31

Сургут (3462)77-98-35  
Тверь (4822)63-31-35  
Томск (3822)98-41-53  
Тула (4872)74-02-29  
Тюмень (3452)66-21-18  
Ульяновск (8422)24-23-59  
Уфа (347)229-48-12  
Хабаровск (4212)92-98-04  
Челябинск (351)202-03-61  
Череповец (8202)49-02-64  
Ярославль (4852)69-52-93

<https://omer.nt-rt.ru> || [orw@nt-rt.ru](mailto:orw@nt-rt.ru)

## AUTOMOTIVE AND LIGHT TRUCK GENERAL SERVICE DESIGNED AND BUILT IN ITALY, AND USED BY THE WORLD'S PREMIUM CAR MANUFACTURERS

# DOUBLE SCISSOR FLY 35

FULL-RISE PAD STYLE

7,700 LB./3.5T CAPACITY

COMPACT DESIGN WITH OVERALL WIDTH OF  
80"/2030MM RAISED HEIGHT OF 74.4"/1890MM



### FEATURES



▲  
Volumetric Control



▲  
Extended Ramps for low clearance vehicles and Hot-Dip Galvanization as optional accessories



▲  
Flush or Surface Mounted

# DOUBLE SCISSOR

## 7,700 LB. / 3.5T CAPACITY

AT OMER USA, OUR GOAL IS TO BUILD LIFTS THAT LAST LONGER, PERFORM BETTER, AND COST LESS TO OPERATE.

| SPECIFICATIONS                 |                                    |
|--------------------------------|------------------------------------|
| Capacity                       | 7,700 lbs. / 3.5T                  |
| Overall Length - Surface Mount | 83.3" / 2115mm                     |
| Overall Length - Flush Mount   | 83.3" / 2115mm                     |
| Overall Width                  | 80" / 2030mm                       |
| Width Between Runways          | 31.5" / 800mm - Adjustable         |
| Deck Width                     | 24.2" / 615mm                      |
| Lowered Height                 | 4.5" / 115mm                       |
| Raised Height                  | 74.4" / 1890mm                     |
| Lifting Time                   | 55 Secs. Raised / 30 Secs. Lowered |
| Power Requirements             | 230 Volts - 60 Hz - 1 PH - 23amp   |
| Shipping Weight                | 1,870 lbs / 850kg                  |
| Part Number                    | OMRFLY35UL                         |

### FEATURES

- Built to higher standard of quality; made in Italy by O.ME.R S.p.A., a world leader in Lift Manufacturing for over 40 years in an ISO 9001 facility.
- No "post" design – Incorporating a smaller footprint than traditional 2-post lifts which maximizes efficiency and productivity of the shop floor.
- Electro-hydraulic double scissor lift, frame contact, low profile with oversized platforms, able to lift most types of vehicle.
- OMER's FLY incorporates a single cylinder on each platform with pneumatically activated safety lock.
- Ultra low-profile max height 4.5" for an easy and comfortable installation without requiring pits for the inground version.
- Lift without electronic sensors, increasing reliability.
- Multiple safeties integrated into design, involving velocity fuse on each cylinder, max pressure valve, acoustic warning for the final descent, low voltage control circuit (24v) and "dead-man" controls.
- Hydraulic and mechanical synchronization system - simple and reliable.
- ALI Certified
- Hot-Dipped Galvanization of the whole structure as an option, offering extra protection from corrosion due to water or salt exposure, extending the life of the equipment.

### EQUIPMENT FOOTPRINT

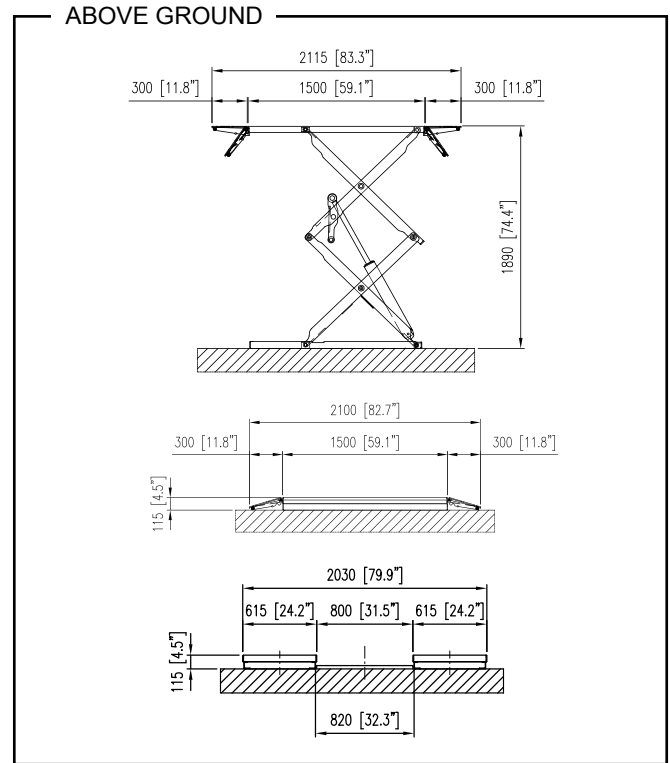

### OPTIONAL ACCESSORIES

- Hot Dipped Galvanized
- Optional 3-phase Power Supply
- Low Approach Ramps
- Traverse Kit

Архангельск (8182)63-90-72  
 Астана (7172)727-132  
 Астрахань (8512)99-46-04  
 Барнаул (3852)73-04-60  
 Белгород (4722)40-23-64  
 Брянск (4832)59-03-52  
 Владивосток (423)249-28-31  
 Волгоград (844)278-03-48  
 Вологда (8172)26-41-59  
 Воронеж (473)204-51-73  
 Екатеринбург (343)384-55-89  
 Иваново (4932)77-34-06

Ижевск (3412)26-03-58  
 Иркутск (395)279-98-46  
 Казань (843)206-01-48  
 Калининград (4012)72-03-81  
 Калуга (4842)92-23-67  
 Кемерово (3842)65-04-62  
 Киров (8332)68-02-04  
 Краснодар (861)203-40-90  
 Красноярск (391)204-63-61  
 Курск (4712)77-13-04  
 Липецк (4742)52-20-81  
 Киргизия (996)312-96-26-47

Магнитогорск (3519)55-03-13  
 Москва (495)268-04-70  
 Мурманск (8152)59-64-93  
 Набережные Челны (8552)20-53-41  
 Нижний Новгород (831)429-08-12  
 Новокузнецк (3843)20-46-81  
 Новосибирск (383)227-86-73  
 Омск (3812)21-46-40  
 Орел (4862)44-53-42  
 Оренбург (3532)37-68-04  
 Пенза (8412)22-31-16  
 Россия (495)268-04-70

Пермь (342)205-81-47  
 Ростов-на-Дону (863)308-18-15  
 Рязань (4912)46-61-64  
 Самара (846)206-03-16  
 Санкт-Петербург (812)309-46-40  
 Саратов (845)249-38-78  
 Севастополь (8692)22-31-93  
 Симферополь (3652)67-13-56  
 Смоленск (4812)29-41-54  
 Сочи (862)225-72-31  
 Ставрополь (8652)20-65-13  
 Казахстан (772)734-952-31

Сургут (3462)77-98-35  
 Тверь (4822)63-31-35  
 Томск (3822)98-41-53  
 Тула (4872)74-02-29  
 Тюмень (3452)66-21-18  
 Ульяновск (8422)24-23-59  
 Уфа (347)229-48-12  
 Хабаровск (4212)92-98-04  
 Челябинск (351)202-03-61  
 Череповец (8202)49-02-64  
 Ярославль (4852)69-52-93