

Архангельск (8182)63-90-72
Астана (7172)727-132
Астрахань (8512)99-46-04
Барнаул (3852)73-04-60
Белгород (4722)40-23-64
Брянск (4832)59-03-52
Владивосток (423)249-28-31
Волгоград (844)278-03-48
Вологда (8172)26-41-59
Воронеж (473)204-51-73
Екатеринбург (343)384-55-89
Иваново (4932)77-34-06

Ижевск (3412)26-03-58
Иркутск (395)279-98-46
Казань (843)206-01-48
Калининград (4012)72-03-81
Калуга (4842)92-23-67
Кемерово (3842)65-04-62
Киров (8332)68-02-04
Краснодар (861)203-40-90
Красноярск (391)204-63-61
Курск (4712)77-13-04
Липецк (4742)52-20-81
Киргизия (996)312-96-26-47

Магнитогорск (3519)55-03-13
Москва (495)268-04-70
Мурманск (8152)59-64-93
Набережные Челны (8552)20-53-41
Нижний Новгород (831)429-08-12
Новокузнецк (3843)20-46-81
Новосибирск (383)227-86-73
Омск (3812)21-46-40
Орел (4862)44-53-42
Оренбург (3532)37-68-04
Пенза (8412)22-31-16
Россия (495)268-04-70

Пермь (342)205-81-47
Ростов-на-Дону (863)308-18-15
Рязань (4912)46-61-64
Самара (846)206-03-16
Санкт-Петербург (812)309-46-40
Саратов (845)249-38-78
Севастополь (8692)22-31-93
Симферополь (3652)67-13-56
Смоленск (4812)29-41-54
Сочи (862)225-72-31
Ставрополь (8652)20-65-13
Казахстан (772)734-952-31

Сургут (3462)77-98-35
Тверь (4822)63-31-35
Томск (3822)98-41-53
Тула (4872)74-02-29
Тюмень (3452)66-21-18
Ульяновск (8422)24-23-59
Уфа (347)229-48-12
Хабаровск (4212)92-98-04
Челябинск (351)202-03-61
Череповец (8202)49-02-64
Ярославль (4852)69-52-93

<https://omer.nt-rt.ru> || orw@nt-rt.ru

SOLLEVATORI PER VEICOLI VEHICLE LIFTS

IPPO 42



IPPO 42

 IPPO 42: sollevatore elettroidraulico a doppia forbice in grado di alzare fino a 4.200 kg di portata, migliorando le caratteristiche del precedente Ippo 36 LX grazie a una struttura rinforzata. La complanarità tra le corsie viene gestita dalla fotocellula di controllo e dal divisore master in centralina, che, consentendo l'eliminazione della torsion bar, rende più versatile il sollevatore.

La sua struttura in piatto d'acciaio ad alta resistenza gli assicura eccezionale solidità e lo pone al top tra i prodotti della sua categoria.

Le prolunghe, estraibili a ponte chiuso anche nella versione incassata, offrono massima versatilità di utilizzo; la loro particolare estensione garantisce la presa anche di veicoli a passo lungo tipo SUV.

Il sollevatore è già conforme all'aggiornamento di agosto 2010 della norma europea EN 1493

SISTEMI DI SICUREZZA

- La fotocellula di controllo posta tra le corsie garantisce il parallelismo tra le stesse (grazie al divisore master presente all'interno della centralina);
- grazie alle boccole autolubrificanti, agli ingrassatori e ai perni di generose dimensioni (45 mm) l'IPPO 42 garantisce la massima affidabilità con la minima manutenzione;
- Dispositivo manuale di discesa in caso di mancanza di energia elettrica;
- Lamiera bugnata antiscivolo;
- Cricchi meccanici di sicurezza impediscono la discesa accidentale del veicolo per tutta la corsa verticale con ben 21 posizioni, a partire da 500 mm da terra. La loro particolare ubicazione li rende meno soggetti ad accumulo sporcizia riducendo sensibilmente il rischio di malfunzionamento;
- Valvole di blocco ai pistoni: massima sicurezza dell'operatore e del veicolo in caso di perdita olio;
- Valvole per il controllo del sovraccarico;
- Comandi in bassa tensione;
- Comandi a uomo presente.

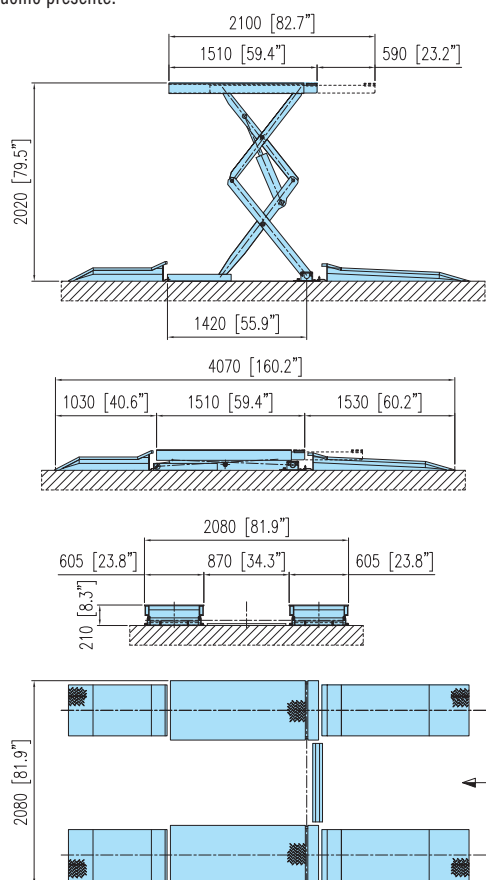

 IPPO 42: a new electro-hydraulic twin scissors lift having a lifting capacity of 4200 kgs. It improves the features of its predecessor Ippo 36 LX thanks to its reinforced structure.

A photocell based system, driven by a master divisor in the control unit, guarantees the leveling between the platforms with no need of a mechanical equipment (torsion bar). The structure is made up of high resistant steel plate assuring exceptional strength at the top of the product range.

The new pull-out platform extensions in the recessed version allow easy use with long wheelbase vehicles such as SUV's.

The lift is already consistent with the updated European norm EN 1493.

SAFETY DEVICES

- the control photocell located between the lift platforms guarantees their full synchronization
- Thanks to the auto-lubricant bushes, greasers and pins having large diameters (45mm), IPPO 42 provides maximum reliability with the minimum of maintenance operations;
- Manual descent device allows for the lift to be lowered in the event of a power failure;
- Embossed anti-slip finish;
- Safety mechanical jacks avoid accidental lowering of the vehicle covering the full vertical height with 21 positions, starting from 500mm to ground level. Their location reduces dirt ingress thus eliminating any malfunction risks;
- Stop valves on the pistons provide maximum safety for the operator and for the vehicles in the event of hydraulic leakages;
- Valves for the overload control;
- Low voltage electrical push button panel;
- Dead-man controls.

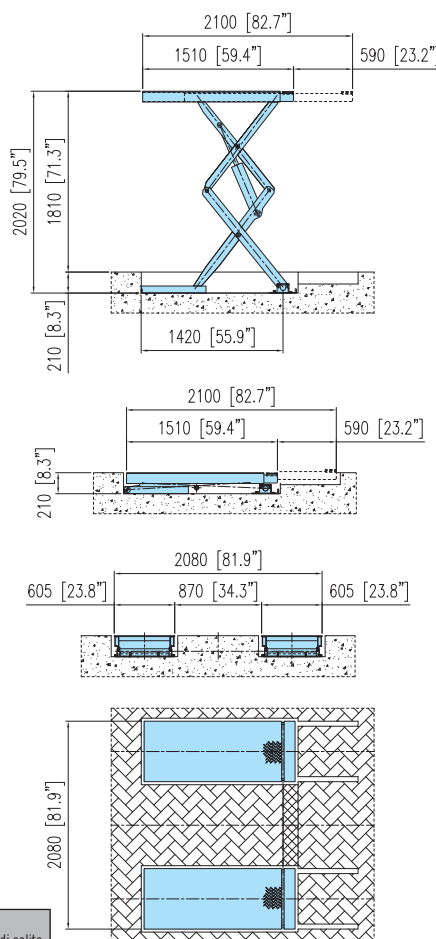

MM / KG INCH / LBS	Capacità Capacity	Alimentazione elettrica - Electric feed	Pressione olio oil pressure	Quantità olio Oil capacity	Peso Gross Weight	Tempo di salita Lifting Time
IPPO 42	4.200 kg 10.000 lbs	230-400V/3/50 Hz 2,5 KW	260 Bar	15 l.	1.110 kg 2.440 lbs	55 s

Архангельск (8182)63-90-72
Астана (7172)727-132
Астрахань (8512)99-46-04
Барнаул (3852)73-04-60
Белгород (4722)40-23-64
Брянск (4832)59-03-52
Владивосток (423)249-28-31
Волгоград (844)278-03-48
Вологда (8172)26-41-59
Воронеж (473)204-51-73
Екатеринбург (343)384-55-89
Иваново (4932)77-34-06

Ижевск (3412)26-03-58
Иркутск (395)279-98-46
Казань (843)206-01-48
Калининград (4012)72-03-81
Калуга (4842)92-23-67
Кемерово (3842)65-04-62
Киров (8332)68-02-04
Краснодар (861)203-40-90
Красноярск (391)204-63-61
Курск (4712)77-13-04
Липецк (4742)52-20-81

Киргизия (996)312-96-26-47

Магнитогорск (3519)55-03-13
Москва (495)268-04-70
Мурманск (8152)59-64-93
Набережные Челны (8552)20-53-41
Нижний Новгород (831)429-08-12
Новокузнецк (3843)20-46-81
Новосибирск (383)227-86-73
Омск (3812)21-46-40
Орел (4862)44-53-42
Оренбург (3532)37-68-04
Пenza (8412)22-31-16

Россия (495)268-04-70

Пермь (342)205-81-47
Ростов-на-Дону (863)308-18-15
Рязань (4912)46-61-64
Самара (846)206-03-16
Санкт-Петербург (812)309-46-40
Саратов (845)249-38-78
Севастополь (8692)22-31-93
Симферополь (3652)67-13-56
Смоленск (4812)29-41-54
Сочи (862)225-72-31
Ставрополь (8652)20-65-13

Казахстан (772)734-952-31

Сургут (3462)77-98-35
Тверь (4822)63-31-35
Томск (3822)98-41-53
Тула (4872)74-02-29
Тюмень (3452)66-21-18
Ульяновск (8422)24-23-59
Уфа (347)229-48-12
Хабаровск (4212)92-98-04
Челябинск (351)202-03-61
Череповец (8202)49-02-64
Ярославль (4852)69-52-93