

Архангельск (8182)63-90-72  
Астана (7172)727-132  
Астрахань (8512)99-46-04  
Барнаул (3852)73-04-60  
Белгород (4722)40-23-64  
Брянск (4832)59-03-52  
Владивосток (423)249-28-31  
Волгоград (844)278-03-48  
Вологда (8172)26-41-59  
Воронеж (473)204-51-73  
Екатеринбург (343)384-55-89  
Иваново (4932)77-34-06

Ижевск (3412)26-03-58  
Иркутск (395)279-98-46  
Казань (843)206-01-48  
Калининград (4012)72-03-81  
Калуга (4842)92-23-67  
Кемерово (3842)65-04-62  
Киров (8332)68-02-04  
Краснодар (861)203-40-90  
Красноярск (391)204-63-61  
Курск (4712)77-13-04  
Липецк (4742)52-20-81

Киргизия (996)312-96-26-47

Магнитогорск (3519)55-03-13  
Москва (495)268-04-70  
Мурманск (8152)59-64-93  
Набережные Челны (8552)20-53-41  
Нижний Новгород (831)429-08-12  
Новокузнецк (3843)20-46-81  
Новосибирск (383)227-86-73  
Омск (3812)21-46-40  
Орел (4862)44-53-42  
Оренбург (3532)37-68-04  
Пенза (8412)22-31-16

Россия (495)268-04-70

Пермь (342)205-81-47  
Ростов-на-Дону (863)308-18-15  
Рязань (4912)46-61-64  
Самара (846)206-03-16  
Санкт-Петербург (812)309-46-40  
Саратов (845)249-38-78  
Севастополь (8692)22-31-93  
Симферополь (3652)67-13-56  
Смоленск (4812)29-41-54  
Сочи (862)225-72-31  
Ставрополь (8652)20-65-13

Казахстан (772)734-952-31

Сургут (3462)77-98-35  
Тверь (4822)63-31-35  
Томск (3822)98-41-53  
Тула (4872)74-02-29  
Тюмень (3452)66-21-18  
Ульяновск (8422)24-23-59  
Уфа (347)229-48-12  
Хабаровск (4212)92-98-04  
Челябинск (351)202-03-61  
Череповец (8202)49-02-64  
Ярославль (4852)69-52-93

<https://omer.nt-rt.ru> || [orw@nt-rt.ru](mailto:orw@nt-rt.ru)

**DEPENDENT DOUBLE AND TRIPLE STACKERS FOR PARKING OR STORAGE APPLICATIONS  
DESIGNED AND BUILT IN ITALY, AND USED BY THE WORLD'S  
PREMIUM CAR MANUFACTURERS**

# BIPARK

## DEPENDENT CAR STACKER

**5,700 TO 7,000 LB./2.6T TO 3.2T CAPACITY PER PLATFORM**

**RUGGED, COMPACT AND DESIGNED FOR REPEATABILITY**



# BIPARK

## 5,700 TO 7,000 LB./2.6T TO 3.2T CAPACITY PER PLATFORM

AT OMER USA, OUR GOAL IS TO BUILD LIFTS THAT LAST LONGER, PERFORM BETTER, AND COST LESS TO OPERATE.

SPECIFICATIONS	BIPARK			
	BIPARK 26	BIPARK 26 H 21	BIPARK 32	
Capacity per platform	5,727 lb./2.6T	5,727 lb./2.6T	7,048 lb./3.2T	5,510 lb./2.5T
Standard Lifting Heights *	72.8"/1.850mm	82.7"/2.100mm	82.7"/2.100mm	70.5"-66.9" - 76" 1.790mm-1.700mm -1.930mm
Standard Platform *	72.8" x 142.5"	86.6" x 142.5"	94.5" x 142.5"	81.5" x 142.5" / 85.6" x 142.5"
Net Height *	9.8"/3.000mm	11.2"/3.420mm	11.2"/3.420mm	19.3"/5.800mm
Power	2.0 hp/1.5 kw	2.0 hp/1.5 kw	2.0 hp/1.5 kw	3.4 hp/2.5 kw
Up/down Travel Time	52/45s	52/45s	52/45s	40/20s (lower platform) 75/40s (upper platform)
Power supply	220V/1Ph/50-60Hz	220V/1Ph/50-60Hz	220V/1Ph/50-60Hz	230V-460V/3Ph/ 50-60Hz
Standard Weight	2,247 lbs/1,020 Kg	2,643 lbs/1,200 Kg	2,863 lbs/1,300 Kg	5,066 lbs/2,300 kg
Part Number	OMR-BIPK26	OMR-BIPK26H21	OMR-BIPK32	OMR-TRIPK25

\* Standard dimension listed - Dimensions can be customized per application

### FEATURES

- Built to a higher standard of quality; made in Italy by O.M.E.R S.p.A., a world leader in Vehicle Lift Manufacturing with over 40 years' experience.
- Compact design—utilizing a minimal footprint, optimizing efficiency and allowing for the maximum number of vehicles in a given space.
- Safety and convenience—the electrically-actuated mechanical-locking device guarantees a safe locking position at 1" intervals, while the unique torsion bar ensures that the platform remains constantly parallel and can be safely stopped at any height.
- Efficiency & Longer Life Time – The platform carriage is guided by wheels and reinforced nylon guides, reducing the friction between the column and carriage and lowering the power needed for operation. Channeled galvanized platforms reduce rust & drain water away from the vehicle below.
- Flexibility – uniquely balanced and reinforced to allow vehicles to be parked facing either forward or backward, with no need for weight to be evenly distributed.

### EQUIPMENT FOOTPRINT

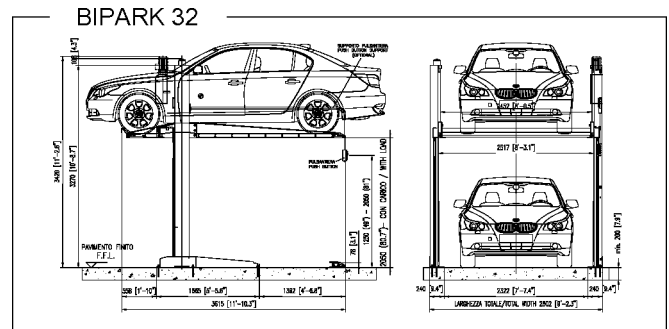
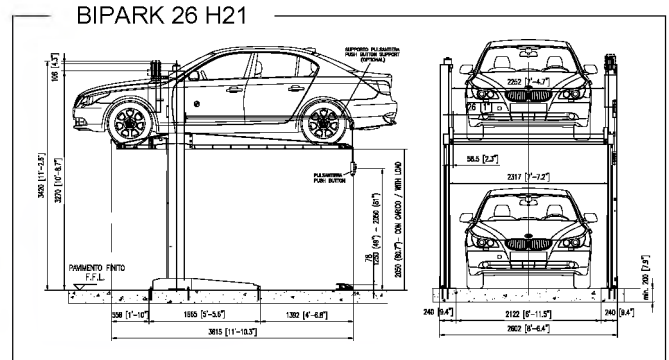
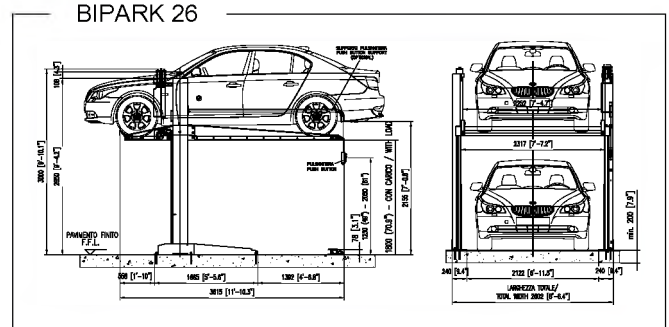

Архангельск (8182)63-90-72  
Астана (7172)727-132  
Астрахань (8512)99-46-04  
Барнаул (3852)73-04-60  
Белгород (4722)40-23-64  
Брянск (4832)59-03-52  
Владивосток (423)249-28-31  
Волгоград (844)278-03-48  
Вологда (8172)26-41-59  
Воронеж (473)204-51-73  
Екатеринбург (343)384-55-89  
Иваново (4932)77-34-06

Ижевск (3412)26-03-58  
Иркутск (395)279-98-46  
Казань (843)206-01-48  
Калининград (4012)72-03-81  
Калуга (4842)92-23-67  
Кемерово (3842)65-04-62  
Киров (8332)68-02-04  
Краснодар (861)203-40-90  
Красноярск (391)204-63-61  
Курск (4712)77-13-04  
Липецк (4742)52-20-81  
Киргизия (996)312-96-26-47

Магнитогорск (3519)55-03-13  
Москва (495)268-04-70  
Мурманск (8152)59-64-93  
Набережные Челны (8552)20-53-41  
Нижний Новгород (831)429-08-12  
Новокузнецк (3843)20-46-81  
Новосибирск (383)227-86-73  
Омск (3812)21-46-40  
Орел (4862)44-53-42  
Оренбург (3532)37-68-04  
Пенза (8412)22-31-16  
Россия (495)268-04-70

Пермь (342)205-81-47  
Ростов-на-Дону (863)308-18-15  
Рязань (4912)46-61-64  
Самара (846)206-03-16  
Санкт-Петербург (812)309-46-40  
Саратов (845)249-38-78  
Севастополь (8692)22-31-93  
Симферополь (3652)67-13-56  
Смоленск (4812)29-41-54  
Сочи (862)225-72-31  
Ставрополь (8652)20-65-13  
Казахстан (772)734-952-31

Сургут (3462)77-98-35  
Тверь (4822)63-31-35  
Томск (3822)98-41-53  
Тула (4872)74-02-29  
Тюмень (3452)66-21-18  
Ульяновск (8422)24-23-59  
Уфа (347)229-48-12  
Хабаровск (4212)92-98-04  
Челябинск (351)202-03-61  
Череповец (8202)49-02-64  
Ярославль (4852)69-52-93